

BBA212 Paint Scale

BBA212 Paint Scale

Economic and fit for purpose



Perfect readability

The big backlit LCD display is easy to read even under difficult light conditions.



True industrial design

The BBA212 has been developed for the ruggedness of the automotive body shop environment.



Adjustable display angle

The angle of the display can be adjusted to allow for ergonomic working



Easy to connect

The BBA212 comes standard with a serial interface for direct connection to a PC.



BBA212

The BBA212 is the most economic way to get an accurate and reliable scale with the well known METTLER TOLEDO quality for your body shop. With a weighing range of 5kg and a readability of 0.1g you are fit for all tasks you will encounter. Thanks to the serial interface you can connect the BBA212 to a PC and use the scale directly with various mixing software packages from leading paint manufacturers.

METTLER TOLEDO

Operation and Maintenance

The BBA212 paint scale can be used as stand alone scale or in connection with a PC, where you run your paint mixing software. Internal software filter allow for accurate measurement even under difficult conditions. Maintenance of the scale is very easy: In case you pour paint over the weighing base, it can easily be cleaned thanks to the stainless steel platform.

Dimensions of the BBA212 Scale (mm)

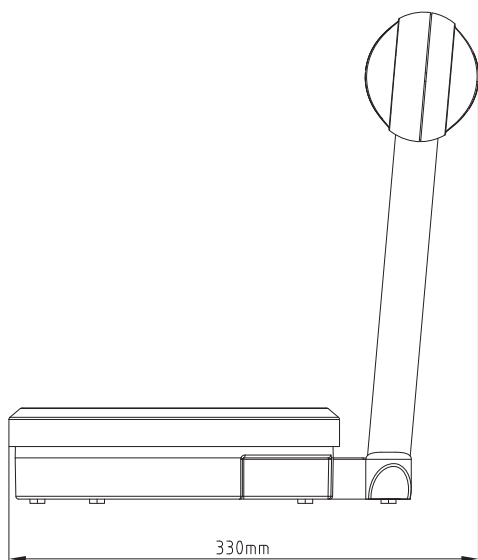
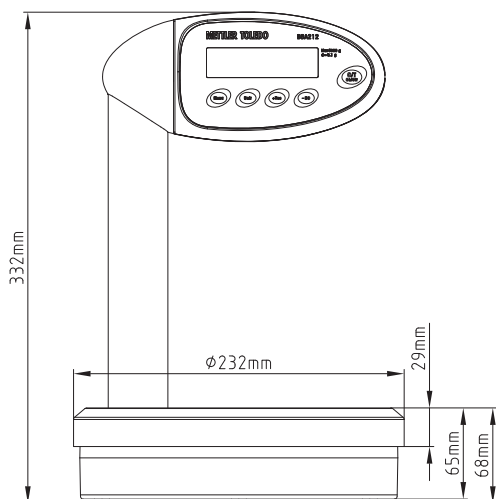

Technical data

BBA212 Paint Scale

Capacity	0 – 5 kg
Readability	0.1g
Units	g, oz, parts (1 part = 1/32 oz)
Display	7 segment LCD with switchable LED backlight Character height 12 mm
Keypad languages	English, Chinese
Software filters	Built in selectable process and vibration adapters
Stabilisation time	Approx 1 sec
Keypad	4 function keys
Housing	Cast aluminum
Platform	Stainless steel
Protection	IP54
Interfaces	RS232, connectable to various color mixing systems
Power supply	Input: 100 – 240 VAC; 50/60 Hz Output: 12.0VDC; 600 mA
Ambient temperature range	5°C to +35°C
Relative humidity	20 – 80% RH
Net/Gross weight	3.8kg/4.5kg

Models

BBA212
BBA212chi

Description

English keypad
Chinese keypad



Mettler-Toledo AG

CH-8606 Greifensee
Switzerland
Tel. +41 44 944 22 11
Fax +41 44 944 30 60

Subject to technical changes
©06/2009 Mettler-Toledo AG
MTSI xxxxxxxx

www.mt.com

For more information